

VANGUARD[®]

BATTERY SYSTEMS



**CHARGED WITH
INNOVATION.**

**Vanguard[®] Lithium-Ion
Commercial Battery Packs**



Our Battery Story.

Our vision was to create a battery like no other.

THE BATTERY CHALLENGE.

It began in 2013 when Vanguard was looking for an electrification partner who had a clear understanding of the commercial market's needs — and had the ability to manufacture a battery solution that could power a broad range of applications. The battery solution would require a unique design to enable easy integration and would need to facilitate scalability based on specific power requirements. Our vision was to create a battery solution like no other — one that could endure extreme operating conditions, be dust and water resistant, withstand being pressure washed, and be easily serviceable. To achieve this goal would take a partner who could provide all of this without requiring significant volume commitments from the OEM and deliver these smaller quantities with short lead times.

THE BATTERY SOLUTION.

It soon became clear that no other partner could meet our high standards, and we enthusiastically committed to designing and manufacturing our own Vanguard integrated lithium-ion battery systems in-house. Owning and controlling the battery production while providing our extensive power application engineering expertise to OEMs has enabled Vanguard to establish itself as a battery power solution provider of choice. In addition, our ability to offer integrative battery solutions, scalability and supply has ensured seamless integration of Vanguard batteries into a range of applications for small, medium, and large OEMs. Vanguard provides a electrified power solution package tailored to meet a broad range of needs. We offer OEMs a complete commercial battery solution together with application engineering support and a global after-sales service and support network.

OUR PROMISE.

Providing a total solution in terms of battery, BMS and charger together with application engineering support to ensure seamless integration into your equipment.

Electrification. Integration. Scalability.

- 1 RELIABLE POWER.** Wrapped in a sealed enclosure, Vanguard batteries are built to withstand vibration, dust, and dirt, and to be pressure-washed once the job is done.
- 2 SAFETY BY DESIGN.** The integrated battery management system (BMS) is responsible for the remarkable safety of Vanguard batteries.
- 3 EASY INTEGRATION. NO HASSLE.** The battery modular design and use of standardized cylindrical cell formats (18650 / 21700) allow Vanguard to keep the same battery pack dimensions even if there will be new technology available in the future.
- 4 AS GOOD AS ITS WORST CELL.** Vanguard works with Tier-1 cell manufacturers and uses their top-quality cells specified with very tight tolerances. Then we make them even tighter.
- 5 COLD WEATHER CHARGING.** Vanguard batteries are specifically designed for cold weather charging from -10°C. And even at freezing temperatures when a Vanguard battery never warms up above 0°C, it still will be able to charge up to 60% SOC.
- 6 GLOBAL SUPPORT.** From pre-production power integration, through sales and marketing, distribution, to infield service and support in more than 100 countries. That's Vanguard.

A TOTAL BATTERY SOLUTION — AN INTEGRATED BATTERY SYSTEM FOR A BROAD RANGE OF APPLICATIONS.



BATTERY



**BATTERY
MANAGEMENT
SYSTEM (BMS)**

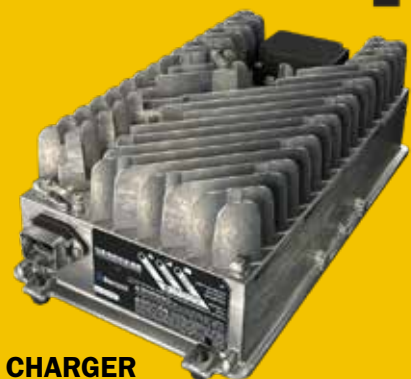

CHARGER



Fi Series

- > Designed to integrate seamlessly into any equipment.
- > Integrated Battery Management System (BMS) that ensures safe operations.
- > Unique Cell Module Assembly (CMA) design.
- > Can be combined in parallel for additional capacity.



AVAILABLE
JANUARY 2023

48V 3,5 kWh[†] Fixed Battery Pack – Fi3,5

RELIABLE POWER. EASY INTEGRATION.

Wrapped in a sealed, compact aluminum diecast enclosure, the Vanguard Fi3,5 3,5 kWh[†] / 48 V fixed commercial battery packs are built to withstand vibration, dust, and dirt, and to be pressure-washed once the job is done. Featuring an integrated battery management system and standard CAN J1939 communication (optional dual communication via CAN Open), these batteries provide reliable power and lower total cost of ownership for a broad range of electrified applications from 3,5 to 35,0 kWh[†] 196 LG M50L cells inside.

3,5
Nominal Energy (kWh[†])

51,6
Nominal Voltage (V)

67
Discharge current (A)

2000
Durability (cycles)

BATTERY FEATURES:

- > Battery Management System (BMS)
- > Dual CANbus communication
- > Plug-in ready charging system
- > Ingress protection rating IP66 and pressure washer
- > Aluminum diecast enclosure
- > Up to 10 batteries parallel capability
- > No scheduled maintenance needs



DIMENSIONS (mm, [in])

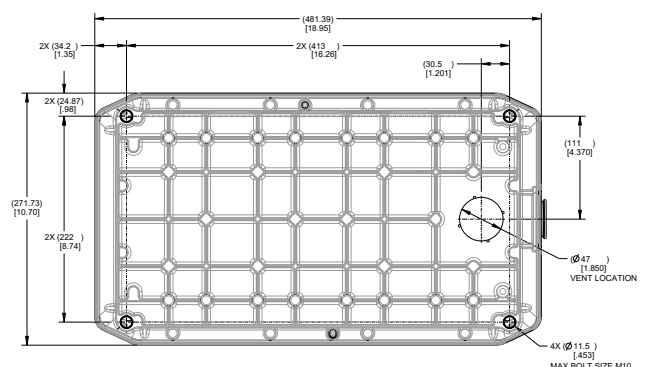
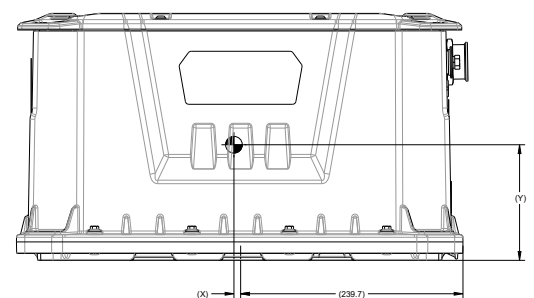
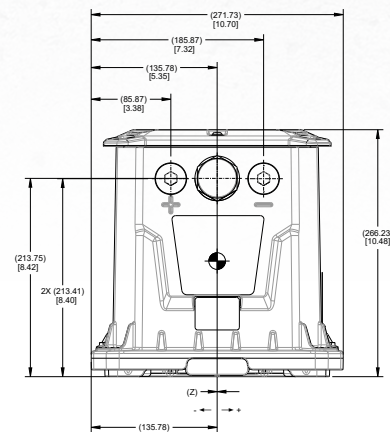

Battery Type	Fixed battery pack - Fi3,5 Lithium-ion integrated Battery Management System
--------------	---

Model Number	80110583
--------------	----------

Nominal Voltage (V)	51,6
---------------------	------

Top Voltage (V)	58,8
-----------------	------

Cut-off Voltage (V)	35,0
---------------------	------

Nominal Capacity / Energy (Ah / kWh [†])	67,5 / 3,5 [†]
--	-------------------------

Weight (kg)	31,8
-------------	------

Durability (Cycles) at 80% Capacity Retention	Up to 2000
---	------------

Charge time (hours)	4
---------------------	---

Dimensions L x W x H (mm)	505 x 292 x 266
---------------------------	-----------------

[†] Total energy measured using a 0,2C discharge per IEC 61960-3:2017.

* The battery pack is silent, however the application itself may make noise.

** See www.vanguardpower.com for warranty details.

48V 5,0 kWh[†] Fixed Battery Pack – Fi5,0

RELIABLE POWER. EASY INTEGRATION.

Wrapped in a sealed, tall HDPE enclosure with outer metal roll-cage, the Vanguard Fi5,0 5,0 kWh[†] / 48 V fixed commercial battery packs are built to withstand vibration, dust, and dirt, and to be pressure-washed once the job is done. Featuring an integrated battery management system and standard CAN J1939 communication (optional dual communication via CAN Open), these batteries provide reliable power and lower total cost of ownership for a broad range of electrified applications from 5,0 to 50,0 kWh[†] 448 LG MH1 cells inside.

5,1

Nominal Energy (kWh[†])

51,6

Nominal Voltage (V)

100

Discharge current (A)

2000

Durability (cycles)

BATTERY FEATURES:

- > Battery Management System (BMS)
- > Dual CANbus communication
- > Plug-in ready charging system
- > Ingress protection rating IP66 and pressure washer
- > HDPE rollcage enclosure
- > Aluminum outer shell
- > Cast aluminum base
- > Up to 10 batteries parallel capability
- > No scheduled maintenance needs

Battery Type	Fixed battery pack - Fi5,0 Lithium-ion integrated Battery Management System
Model Number	80111266
Nominal Voltage (V)	51,6
Top Voltage (V)	58,8
Cut-off Voltage (V)	35,0
Nominal Capacity / Energy (Ah / kWh [†])	98,7 / 5,1 [†]
Weight (kg)	48
Durability (Cycles) at 80% Capacity Retention	Up to 2000
Charge time (hours)	5,5
Dimensions L x W x H (mm)	591 x 266 x 366



DIMENSIONS (mm, [in])

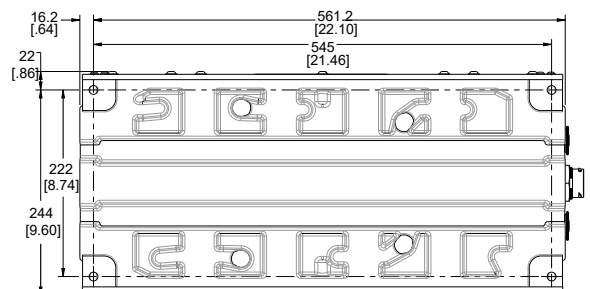
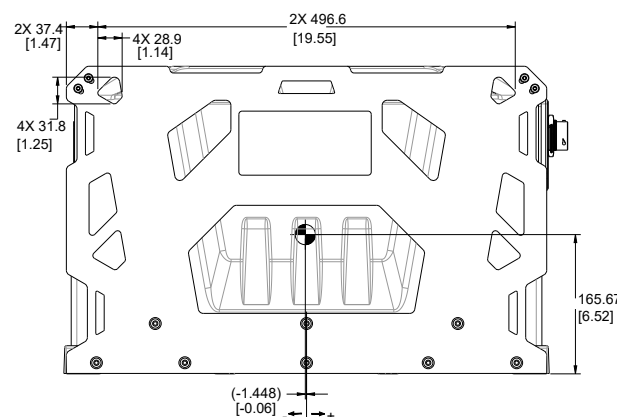
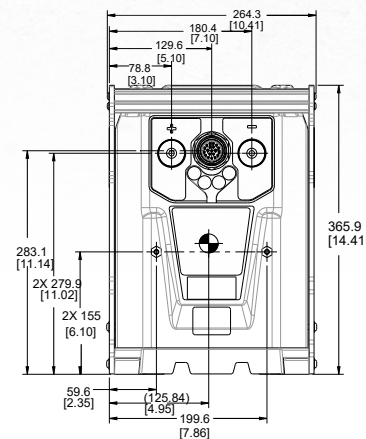

[†] Total energy measured using a 0,2C discharge per IEC 61960-3:2017.

* The battery pack is silent, however the application itself may make noise.

** See www.vanguardpower.com for warranty details.

AVAILABLE
JANUARY 2023

48V 5,0 kWh[†] Fixed Battery Pack – Fi5,0

RELIABLE POWER. EASY INTEGRATION.

Wrapped in a sealed, tall aluminum diecast enclosure, the Vanguard Fi5,0 5,0 kWh[†] / 48 V fixed commercial battery packs are built to withstand vibration, dust, and dirt, and to be pressure-washed once the job is done. Featuring an integrated battery management system and standard CAN J1939 communication (optional dual communication via CAN Open), these batteries provide reliable power and lower total cost of ownership for a broad range of electrified applications from 5,0 to 50,0 kWh[†] 280 LG M50L cells inside.

5,1
Nominal Energy (kWh[†])

51,6
Nominal Voltage (V)

100
Discharge current (A)

2000
Durability (cycles)

BATTERY FEATURES:

- > Battery Management System (BMS)
- > Dual CANbus communication
- > Plug-in ready charging system
- > Ingress protection rating IP66 and pressure washer
- > Aluminum diecast enclosure
- > Up to 10 batteries parallel capability
- > No scheduled maintenance needs

Battery Type	Fixed battery pack - Fi5,0 Lithium-ion integrated Battery Management System
Model Number	80112254
Nominal Voltage (V)	51,6
Top Voltage (V)	58,8
Cut-off Voltage (V)	35,0
Nominal Capacity / Energy (Ah / kWh [†])	98,7 / 5,1 [†]
Weight (kg)	42,6
Durability (Cycles) at 80% Capacity Retention	Up to 2000
Charge time (hours)	5,5
Dimensions L x W x H (mm)	597 x 266 x 362



DIMENSIONS (mm, [in])

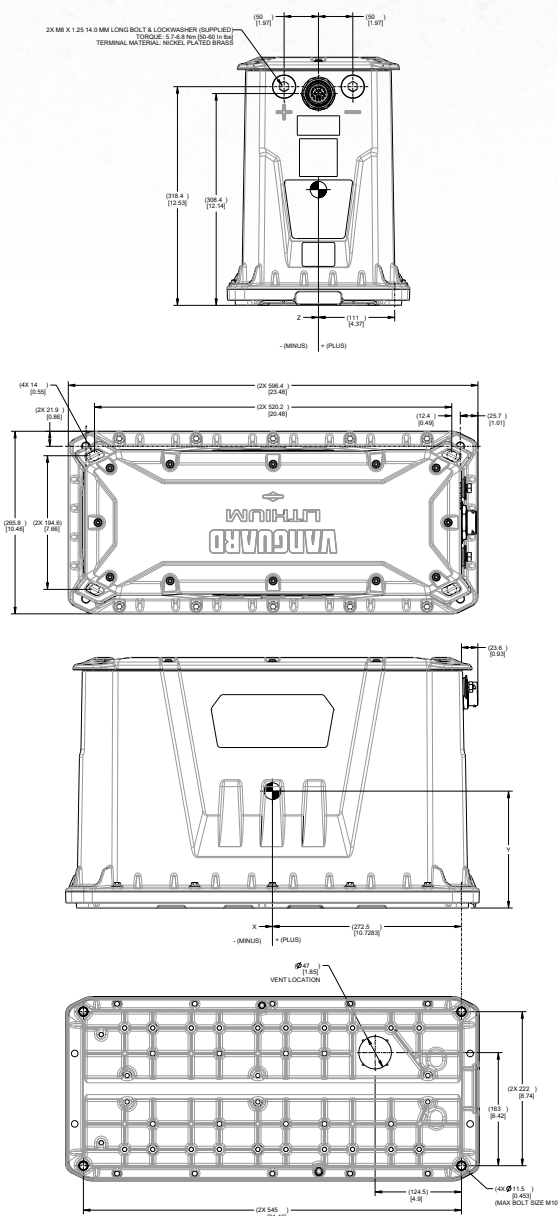

[†] Total energy measured using a 0,2C discharge per IEC 61960-3:2017.

* The battery pack is silent, however the application itself may make noise.

** See www.vanguardpower.com for warranty details.

**AVAILABLE
OCTOBER 2022**

48V 7,0 kWh[†] Fixed Battery Pack – Fi7,0



RELIABLE POWER. EASY INTEGRATION.

Wrapped in a sealed, long aluminum diecast enclosure, the Vanguard Fi7,0 7,0 kWh[†] / 48 V fixed commercial battery packs are built to withstand vibration, dust, and dirt, and to be pressure-washed once the job is done. Featuring an integrated battery management system and standard CAN J1939 communication (optional dual communication via CAN Open), these batteries provide reliable power and lower total cost of ownership for a broad range of electrified applications from 7,0 to 70,0 kWh[†] 392 LG M50L cells inside.



DIMENSIONS (mm, [in])

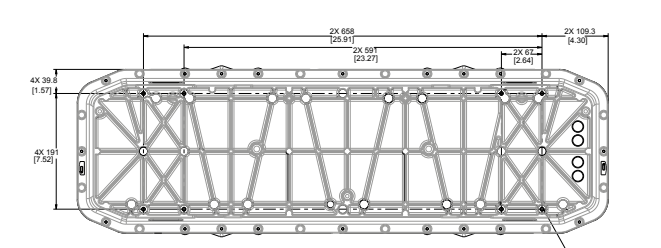
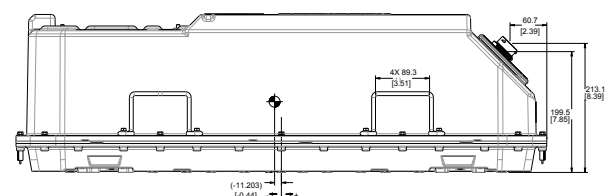
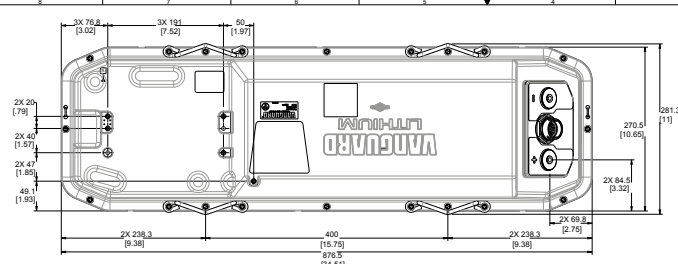
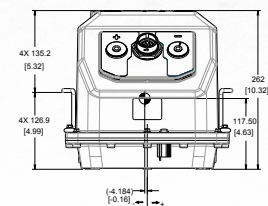

7,0 Nominal Energy (kWh [†])	51,6 Nominal Voltage (V)
134 Discharge current (A)	2000 Durability (cycles)

BATTERY FEATURES:

- > Battery Management System (BMS)
- > Dual CANbus communication
- > Plug-in ready charging system
- > Ingress protection rating IP66 and pressure washer
- > Aluminum diecast enclosure
- > Up to 10 batteries parallel capability
- > No scheduled maintenance needs

Battery Type	Fixed battery pack - Fi7,0 Lithium-ion integrated Battery Management System
Model Number	80104774
Nominal Voltage (V)	51,6
Top Voltage (V)	58,8
Cut-off Voltage (V)	35,0
Nominal Capacity / Energy (Ah / kWh [†])	135,9 / 7,0 [†]
Weight (kg)	52,6
Durability (Cycles) at 80% Capacity Retention	Up to 2000
Charge time (hours)	8
Dimensions L x W x H (mm)	876 x 264 x 284

[†] Total energy measured using a 0,2C discharge per IEC 61960-3:2017.
* The battery pack is silent, however the application itself may make noise.
** See www.vanguardpower.com for warranty details.

AVAILABLE
JANUARY 2023

48V 7,0 kWh[†] Fixed Battery Pack – Fi7,0

RELIABLE POWER. EASY INTEGRATION.

Wrapped in a sealed, tall aluminum diecast enclosure, the Vanguard Fi7,0 7,0 kWh[†] / 48 V fixed commercial battery packs are built to withstand vibration, dust, and dirt, and to be pressure-washed once the job is done. Featuring an integrated battery management system and standard CAN J1939 communication (optional dual communication via CAN Open), these batteries provide reliable power and lower total cost of ownership for a broad range of electrified applications from 7,0 to 70,0 kWh[†] 392 LG M50L cells inside.

7,0
Nominal Energy (kWh[†])

51,6
Nominal Voltage (V)

134
Discharge current (A)

2000
Durability (cycles)

BATTERY FEATURES:

- > Battery Management System (BMS)
- > Dual CANbus communication
- > Plug-in ready charging system
- > Ingress protection rating IP66 and pressure washer
- > Aluminum diecast enclosure
- > Up to 10 batteries parallel capability
- > No scheduled maintenance needs

Battery Type	Fixed battery pack - Fi7,0 Lithium-ion integrated Battery Management System
Model Number	80112214
Nominal Voltage (V)	51,6
Top Voltage (V)	58,8
Cut-off Voltage (V)	35,0
Nominal Capacity / Energy (Ah / kWh [†])	135,9 / 7,0 [†]
Weight (kg)	49,9
Durability (Cycles) at 80% Capacity Retention	Up to 2000
Charge time (hours)	8
Dimensions L x W x H (mm)	597 x 266 x 362



DIMENSIONS (mm, [in])

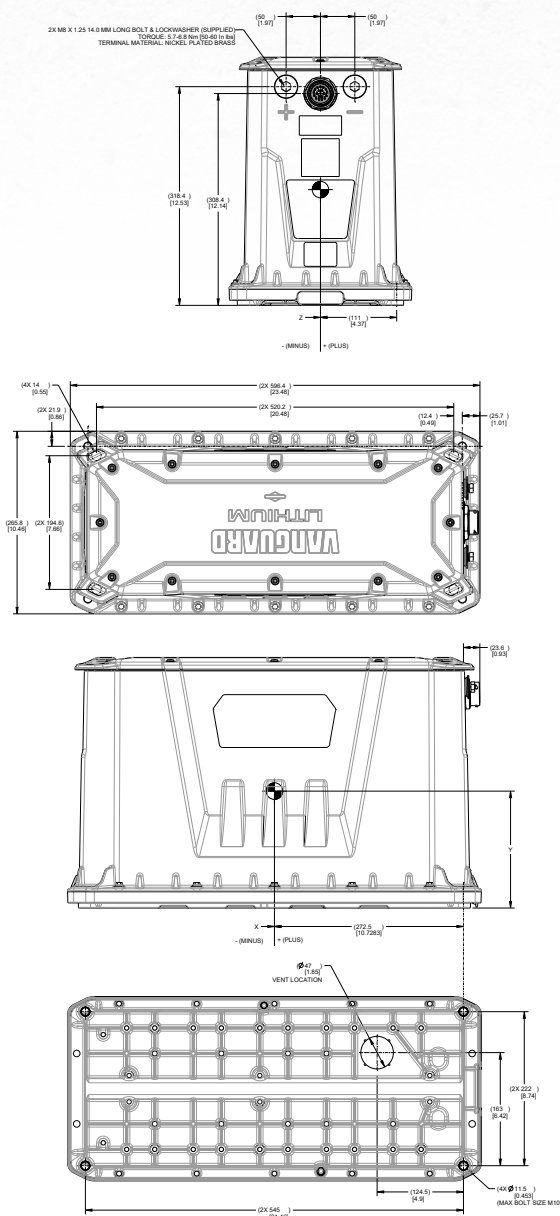

[†] Total energy measured using a 0,2C discharge per IEC 61960-3:2017.

* The battery pack is silent, however the application itself may make noise.

** See www.vanguardpower.com for warranty details.

48V 10,0 kWh[†] Fixed Battery Pack – Fi10,0

RELIABLE POWER. EASY INTEGRATION.

Wrapped in a sealed, tall HDPE enclosure with outer metal roll-cage, the Vanguard Fi10,0 10,0 kWh[†] / 48 V fixed commercial battery packs are built to withstand vibration, dust, and dirt, and to be pressure-washed once the job is done. Featuring an integrated battery management system and standard CAN J1939 communication (optional dual communication via CAN Open), these batteries provide reliable power and lower total cost of ownership for a broad range of electrified applications from 10,0 to 100,0 kWh[†]: 896 LG MH1 cells inside.

10,2

Nominal Energy (kWh[†])

100

Discharge current (A)

51,6

Nominal Voltage (V)

2000

Durability (cycles)

BATTERY FEATURES:

- > Battery Management System (BMS)
- > Dual CANbus communication
- > Plug-in ready charging system
- > Ingress protection rating IP66 and pressure washer
- > HDPE rollcage enclosure
- > Aluminum outer shell
- > Cast aluminum base
- > Up to 10 batteries parallel capability
- > No scheduled maintenance needs

Battery Type	Fixed battery pack - Fi10,0 Lithium-ion integrated Battery Management System
Model Number	80084085
Nominal Voltage (V)	51,6
Top Voltage (V)	58,8
Cut-off Voltage (V)	35,0
Nominal Capacity / Energy (Ah / kWh [†])	197,4 / 10,2 [†]
Weight (kg)	95,3
Durability (Cycles) at 80% Capacity Retention	Up to 2000
Charge time (hours)	9,5
Dimensions L x W x H (mm)	624 x 439 x 366



DIMENSIONS (mm, [in])

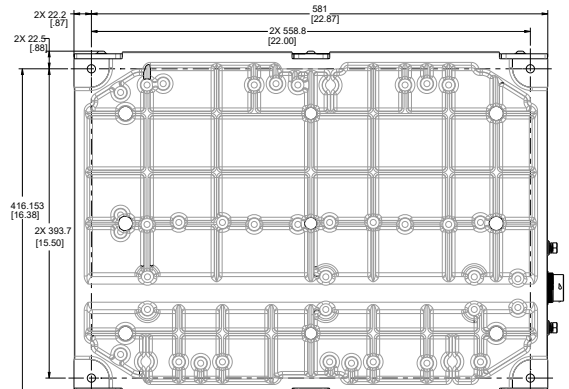
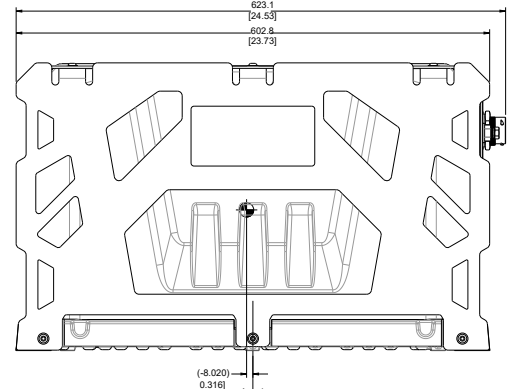
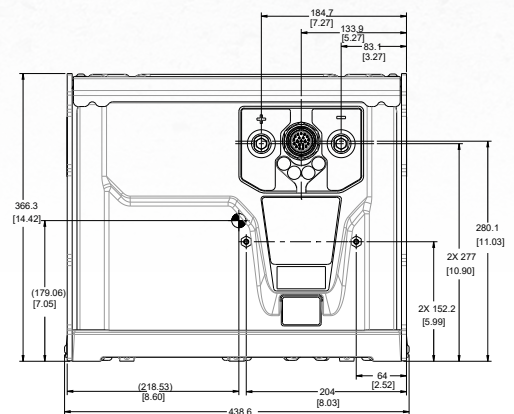

[†] Total energy measured using a 0,2C discharge per IEC 61960-3:2017.

* The battery pack is silent, however the application itself may make noise.

** See www.vanguardpower.com for warranty details.

1050 W Charger & Vanguard Lithium App

1050 W SINGLE-PHASE CHARGING SYSTEM WITH BLUETOOTH® MONITORING

It can be plugged into a standard wall outlet. The charger seamlessly delivers an electrical current from the 230 V outlet to the Vanguard battery. It can be connected in parallel (2) to reduce charging time.

100 – 240 V (AC)
Voltage Range, rated

85 – 265 V (AC)
Voltage Range, operating

SINGLE-PHASE

CHARGER FEATURES:

- > Works seamlessly with battery pack
- > Bluetooth capabilities for monitoring AC Input and DC Output specifications
- > Fast recharge time of 6 hours (5,0 kWh¹) and 12 hours (10,0kWh¹)
- > Can be connected in parallel (2) to reduce charging time
- > Enclosure rating IP66/ NEMA 4
- > The most powerful fan-less on/off-board charger that works on a standard wall outlet
- > Dimensions (L x W x H): 336 x 182 x 113 mm
- > New 3000W charger coming soon

VANGUARD LITHIUM APPLICATION:

- > The Vanguard Lithium application interfaces wirelessly with Vanguard battery chargers over Bluetooth Smart
- > Display diagnostic information related to battery charges
- > Allows users to configure battery chargers
- > Cloud connectivity



VANGUARD LITHIUM APPLICATION

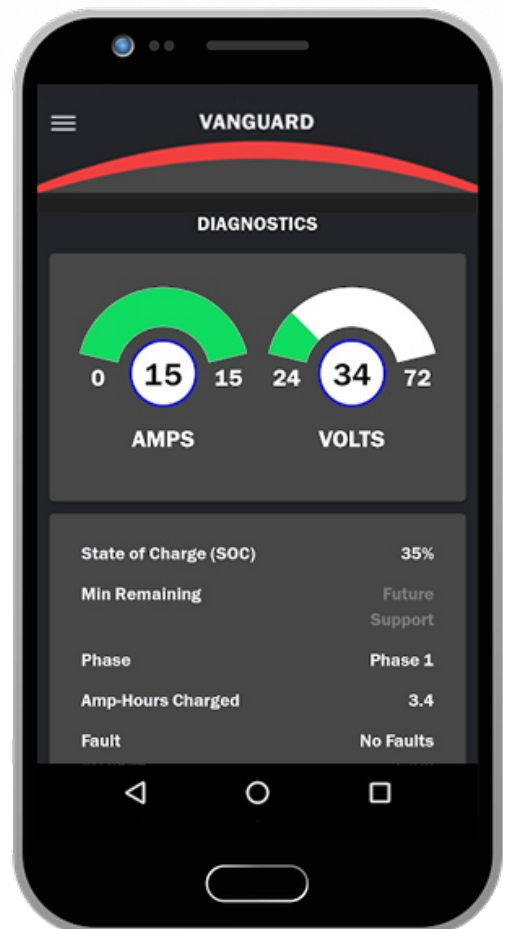

¹ Total energy measured using a 0,2C discharge per IEC 61960-3:2017.
^{*} See www.vanguardpower.com for warranty details.

Si Series



**Available
May 2023**

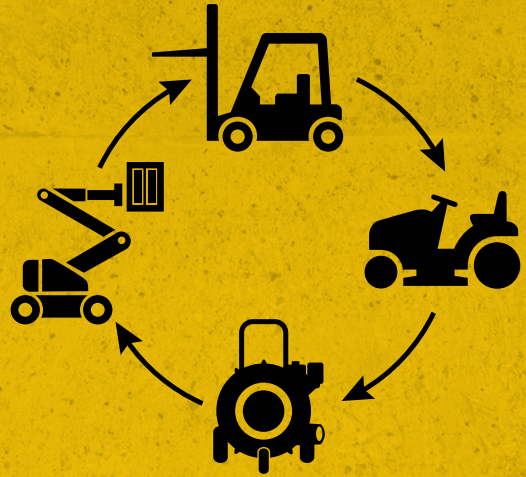

- > Easy swapping between applications at the job site to reduce downtime.
- > Multiple mounting configurations.
- > Integrated Battery Management System (BMS) that ensures safe operations.
- > Quick, tool-less locking and unlocking.
- > Works across multiple products and brands.
- > Can be combined in parallel for additional capacity.

AVAILABLE
MAY 2023

48V 1,5 kWh[†]

Swappable Battery Pack – Si1,5

RELIABLE POWER. EASY INTEGRATION. USER-SWAPPABLE.

Wrapped in a sealed aluminum diecast enclosure, the Vanguard Si1,5 1,5 kWh[†] / 48 V swappable commercial battery packs are built to withstand vibration, dust, and dirt, and to be pressure-washed once the job is done. Featuring an integrated battery management system and standard CAN J1939 communication, these batteries work across multiple brands and applications from 1,5 to 15,0 kWh[†] 98 Molicel P42A cells inside.

1,5

Nominal Energy (kWh[†])

51,4

Nominal Voltage (V)

29

Discharge current (A)

1000

Durability (cycles)

BATTERY FEATURES:

- > Battery Management System (BMS)
- > Single CANbus J1939 communication
- > Plug-in ready charging system
- > Ingress protection rating IP66 and pressure washer
- > Aluminum diecast enclosure
- > Up to 10 batteries parallel capability
- > No scheduled maintenance needs
- > New 1425W swappable charger coming soon

Battery Type	Swappable battery pack - Si1,5 Lithium-ion integrated Battery Management System
--------------	---

Model Number	TBC
Nominal Voltage (V)	51,4
Top Voltage (V)	58,8
Cut-off Voltage (V)	35,0
Nominal Capacity / Energy (Ah / kWh [†])	28,4 / 1,5 [†]
Weight (kg)	11,8
Durability (Cycles) at 80% Capacity Retention	Up to 1000
Charge time (hours)	Less than 2
Dimensions L x W x H (mm)	258 x 136 x 425



[†] Total energy measured using a 0,2C discharge per IEC 61960-3:2017.

* The battery pack is silent, however the application itself may make noise.

** See www.vanguardpower.com for warranty details.

What Can You Power?

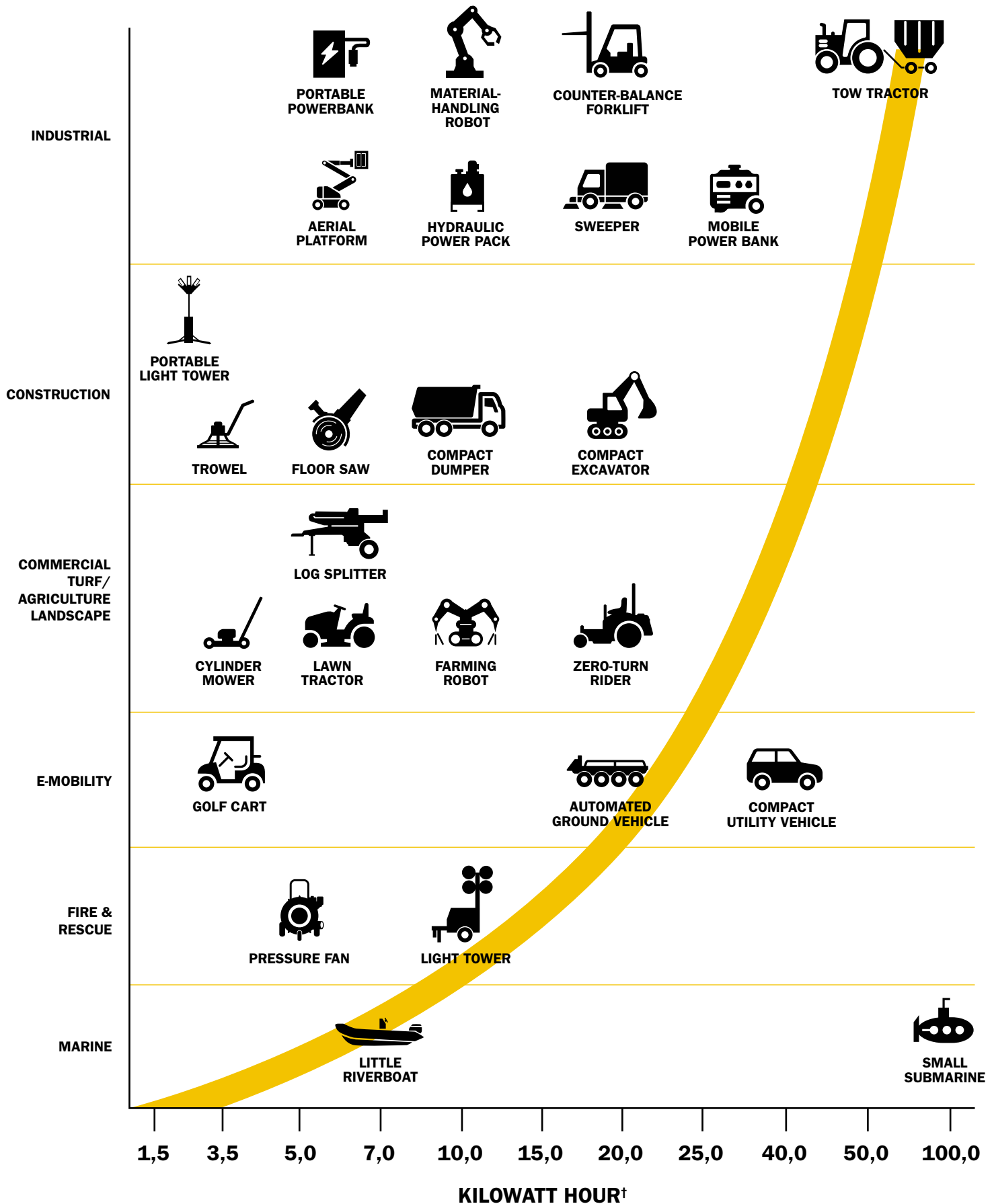

[†] Total energy measured using a 0,2C discharge per IEC 61960-3:2017.

A Powerful Solution.

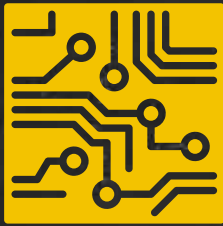

POWER MAP

Vanguard batteries feature a power map programmed on the Battery Management System (BMS). This allows it to know how much power the battery can give in discharge and receive in charge/regen at a given moment, taking into account the voltage, temperature, and state of health of the battery. This helps preserve the life of the battery as well as prevent it from having to shut down due to an over current event. If you follow the Power Map limits, the battery will not interrupt (open the internal contractors).



COLD WEATHER CHARGING (DE-RATED)

Vanguard batteries allow for slow cold weather charging from -10°C . It utilizes a charge current to warm up the battery above 0°C and continue charging at full rate. Vanguard batteries charging temperature range is from -10°C to $+50^{\circ}\text{C}$. If a Vanguard battery never warms up above 0°C , it still will be able to charge up to 60% SOC.



HYBRID MODE

Hybrid Mode is an operating state that a Vanguard battery can be put into. It allows the battery to operate such that it is in Discharge Mode while also charging with Vanguard Chargers.

Hybrid Mode can only be used while the battery is under 80% SOC. If the battery starts under 80% SOC and reaches 80% while in Hybrid Mode, it automatically and seamlessly transitions to Discharge Mode.

Comparing Lead-Acid vs Lithium-Ion Batteries.

The world is changing, and batteries are changing the way we use power as it grows into an increasingly in-demand power source. However, choosing the right battery pack solution for the application of OEMs may feel like unfamiliar territory. There are multiple parameters to consider (including voltage, safety, capacity) that make the process of selecting the best battery a complex task. We're breaking down the main differences between a lead acid battery and a lithium-ion battery for you.

LEAD-ACID



LITHIUM-ION



BATTERY BASICS

- > Very heavy, but can act as a counterweight
- > Rechargeable
- > High surge currents at startup
- > Unsophisticated and simple to function
- > Heat up when charged or discharged, wasting energy
- > Efficiency can drop to as low as 50% during high use
- > Higher self-discharge rate
- > Entire battery must be replaced if 1 cell fails
- > Lower cost, but may not last through entire usage case

- > 5x lighter than lead acid battery
- > Rechargeable
- > No surge current at startup
- > "Smart" — battery management system (BMS) offers temperature monitoring, data on power utilization and voltage, the ability to integrate with Internet of Things (IoT) devices, and more
- > High energy density
- > Up to 93%+ efficiency
- > Low self-discharge rate; holds charge longer
- > Modular, more serviceable design available
- > Battery more likely to last entire life of equipment

SAFETY

- > Plates need to be continuously soaked in a liquid mixture of sulfuric acid and water to operate correctly
- > Dangerous materials; risk of being exposed to acid when watering
- > Acid-resistant PPE required when servicing
- > No safety monitoring
- > No safety backups

- > Maintenance free
- > No exposure to dangerous materials
- > No PPE required to handle battery
- > BMS constantly monitors and measures temperature, charge and discharge currents and voltages of each individual cell bank
- > Safeties in place to reduce potential of thermal runaway, including high temperature shut down

SUSTAINABILITY

- > Recyclable
- > Risk of sulfuric acid and/or lead leakage if damaged or improperly stored
- > Shorter lifecycle
- > Lower IP rating; battery becomes unusable with water intrusion
- > Emissions-free

- > Recyclable + cleaner to produce and consume
- > Particularly environmentally stable and durable
- > Longer lifecycle
- > Higher IP rating; better protection against intrusion, dust, accidental contact, water
- > Emissions-free

What You Need To Consider When Integrating Electrified Power.

The electrification of commercial grade machinery is one of the biggest talking points for OEMs today. Design and manufacture in-house or collaborate with an electrification partner? This is fundamentally the most important decision you will need to make at the beginning of your electrification journey.

When it comes to batteries, sourcing cells and components off the shelf to manufacture your own system seems easier and less capital intensive than with traditional engines – providing an alternative path to gain flexibility, increased customization and ultimately save costs. However, producing and integrating electrification effectively into machinery can be full of potential pitfalls...

So, here is our advice to successfully integrate electrified power:

GAUGE MARKET EXPECTATIONS

Before embarking on your electrification project, you should consider the following: charge times, daily usage (hours used), life expectancy, load conditions, peak power draw, cooling requirements, operating temperatures, work environment, weight and price.

UNDERSTAND REAL-LIFE APPLICATION USAGE

Ensure your team fully understands real-life usage conditions – not just internal testing criteria – in order to qualify a product. Make a comprehensive list of all critical parameters, including but not limited to, power peaks, heat (temperature), current draw, cooling requirements, daily hour usage, user life expectations and load response.

OBTAIN THE RIGHT KNOW-HOW

Work with an established and experienced technology partner who can bring vast electrification and application engineering expertise to the table. While this may incur additional upfront costs, they can streamline the electrification process and save you time and money in the long run.

ACCESS TO NEW TECHNOLOGY

Identify a strong partner who has access to the latest technology from Tier 1 and 2 suppliers. Their economies of scale will give you access to industry-leading technology at a more affordable price point.

UNDERSTAND SAFETY REQUIREMENTS

Lithium-Ion, with the proper system management, is safer, longer-lasting and more powerful than lead-acid. But it is extremely important that your team understands all the safety requirements. Technology partners have this know-how and can ensure you address these critical safety measures in the very early stages of development.



BATTERY TECHNICAL SPECIFICATIONS



	Si1,5 Available May 2023	Fi3,5 Available January 2023	Fi5,0 Available Now
SPECIFICATION	48V 1,5kWh [†]	48V 3,5 kWh ^{††}	48V 5,0kWh [†]
ENCLOSURE MATERIALS	Aluminum	Aluminum	Polymer
NOMINAL VOLTAGE	51,4 V	51,6 V	51,6 V
DISCHARGE CUTOFF VOLTAGE	35,0 V	35,0 V	35,0 V
DISCHARGE CURRENT, NOMINAL	100 A	67 A	100 A
DISCHARGE CURRENT, MAX. CONTINUOUS	100 A	168 A	200 A
DISCHARGE CURRENT, 10S SURGE	180 A	200 A	300 A
NOMINAL CAPACITY (PER IEC61960)	28,4 Ah	67,5 Ah	98,7 Ah
NOMINAL ENERGY (PER IEC61960)	1,5 kWh [†]	3,5 kWh [†]	5,1 kWh [†]
DISCHARGE TEMPERATURE RANGE	-40 °C to + 70°C	-20°C to +70°C	-20 °C to + 70°C
PARALLEL CAPABLE	Yes	Yes	Yes
MARKETED DURABILITY	Up to 1000 cycles to 80% initial capacity	Up to 2,000 cycles to 80% initial capacity	Up to 2000 cycles to 80% initial capacity

CHARGING

CHARGE VOLTAGE (PER IEC61960)	58,8 V	58,8 V	58,8 V
CHARGE TEMPERATURE RANGE	0°C to +45°C	-10°C to +45°C	-10°C to +45°C
CHARGE TIME WITH 1050W VANGUARD® CHARGER	—	4 Hours	5,5 Hours
CHARGE TIME WITH 1425W VANGUARD® CHARGER[§]	< 2 Hours	—	—
CHARGE TIME WITH 3000W VANGUARD® CHARGER[§]	—	2,5 Hours	3 Hours

DIMENSIONS/WEIGHT

PACK FRAME DIMENSIONS (L×W×H), INCHES	10,2 x 5,4 x 16,7	19,9 x 11,5 x 10,5	23,3 x 10,5 x 14,4
PACK FRAME DIMENSIONS (L×W×H), MILLIMETERS	258 x 136 x 425	505 x 292 x 266	591 x 266 x 366
PACK WEIGHT	11,8 kg (26 lbs)	31,8kg (70lbs)	48kg (106 lbs)

[†] Total energy measured using a 0,2C discharge per IEC 61960-3:2017.

^{*} See www.vanguardpower.com for warranty details

^{††} Battery packs are not currently in production are subject to changes at time of production launch.

[§] Coming soon.



Fi5,0 Available January 2023	Fi7,0 Available October 2022	Fi7,0 Available January 2023	Fi 10,0 Available Now
48V 5,0 kWh [†]	48V 7,0 kWh ^{††}	48V 7,0 kWh ^{††}	48V 10,0 kWh [†]
Aluminum	Aluminum	Aluminum	Polymer
51,6 V	51,6 V	51,6 V	51,6 V
35,0 V	35,0 V	35,0 V	35,0 V
100 A	134 A	134 A	100 A
200 A	200 A	200 A	200 A
300 A	400 A	400 A	300 A
98,7 Ah	135,9 Ah	135,9 Ah	197,4 Ah
5,1 kWh	7,0 kWh [†]	7,0 kWh [†]	10,2 kWh [†]
-20°C to +70°C	-20°C to +70°C	-20°C to +70°C	-20°C to +70°C
Yes	Yes	Yes	Yes
Up to 2,000 cycles to 80% initial capacity	Up to 2,000 cycles to 80% initial capacity	Up to 2,000 cycles to 80% initial capacity	Up to 2,000 cycles to 80% initial capacity

58,8 V	58,8 V	58,8 V	58,8 V
-10°C to +45°C	-10°C to +45°C	-10°C to +45°C	-10°C to +45°C
5,5 Hours	8 Hours	8 Hours	9,5 Hours
—	—	—	—
3 Hours	4 Hours	4 Hours	5 Hours

23,3 × 10,5 × 14,4	34,5 × 11,2 × 10,4	23,3 × 10,5 × 14,4	24,5 × 17,3 × 14,4
597 × 266 × 362	876 × 264 × 284	597 × 266 × 362	624 × 439 × 366
42,6kg (94lbs)	52,6kg (116lbs)	49,9kg (110lbs)	95,3kg (210lbs)

Vanguard Battery Technology Partners



VANGUARD

BRIGGS & STRATTON

Wolleraustrasse 41
8807 Freienbach, Switzerland
+41 (0)55 415 1200
Copyright ©2023. All rights reserved.

WWW.VANGUARDPOWER.COM



Discover more about Vanguard battery solutions.